

Operatore elettromeccanico per cancelli scorrevoli industriali

Istruzioni d'uso ed avvertenze

Electromechanical operators for industrial sliding gates

Operating instructions and warnings

Opérateurs électromécaniques pour portails coulissants industriels

Notice d'emploi et avertissements

Elektromechanischer Antrieb für industrielle Schiebetore

Bedienungsanleitung und Hinweise

Operador electromecánico para cancelas correderas industriales

Instrucciones de uso y advertencias

Operador electromecânico para portões de correr industriais

Instruções para utilização e advertências

Napęd elektromechaniczny do przemysłowych bram przesuwnych

Instrukcja montażu i użytkowania

Электромеханические операторы для промышленных раздвижных ворот

Инструкция по эксплуатации и предупреждения

DEA[®]

move as you like



www.deasystem.com

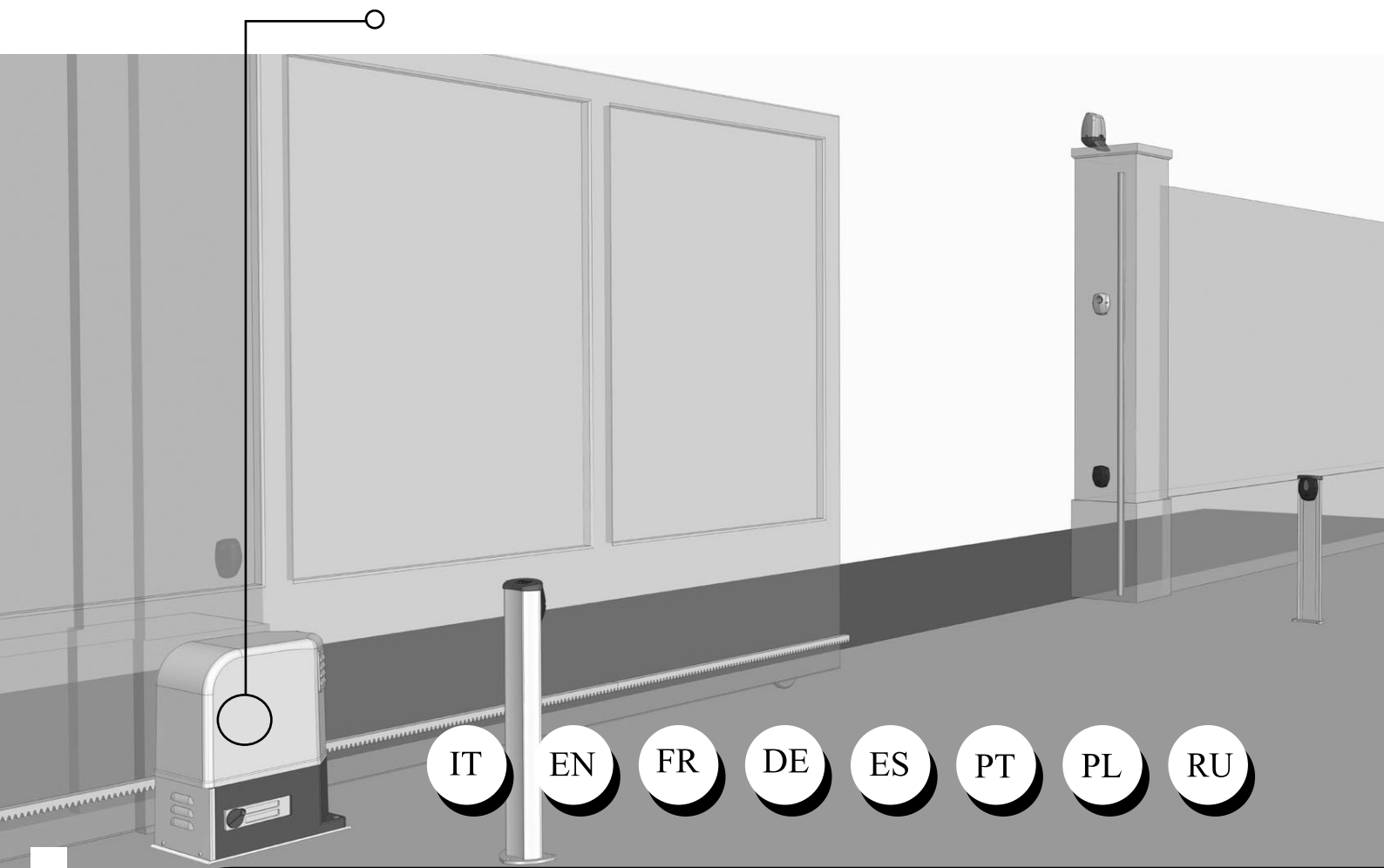

IT

EN

FR

DE

ES

PT

PL

RU

GULLIVER

Index

1	Warnings Summary	EN-1	6	Start-up	EN-7
2	Product Description	EN-3	6.1	Installation Test	EN-7
3	Technical data	EN-3	6.2	Unlocking and manual operation	EN-7
4	Installation and Assembly	EN-4	7	Maintenance	EN-7
5	Electrical Connections	EN-5	8	Product Disposal	EN-8

1 WARNINGS SUMMARY

WARNING! IMPORTANT SAFETY INSTRUCTIONS. CAREFULLY READ AND FOLLOW ALL WARNINGS AND INSTRUCTIONS THAT ACCOMPANY THE PRODUCT SINCE INCORRECT INSTALLATION COULD CAUSE HARM TO PEOPLE, ANIMALS OR THINGS. WARNINGS AND INSTRUCTIONS PROVIDE IMPORTANT INFORMATION REGARDING SAFETY, INSTALLATION, USE AND MAINTENANCE. KEEP THE INSTRUCTIONS TOGETHER WITH THE TECHNICAL DOCUMENTATION AND FOR FUTURE REFERENCE.

⚠ **WARNING** The device may be used by children of less than 8 years of age, people with reduced physical, mental or sensory impairment, or generally anyone without experience or, in any case, the required experience provided the device is used under surveillance or that users have received proper training on safe use of the device and are aware of the dangers related to its use.

⚠ **WARNING** Do not allow children to play with the device, the fixed commands or the radio controls of the system.

⚠ **WARNING** Product use in abnormal conditions not foreseen by the manufacturer may generate hazardous situations; meet the conditions indicated in these instructions.

⚠ **WARNING DEA** System reminds all users that the selection, positioning and installation of all materials and devices which make up the complete automation system, must comply with the European Directives 2006/42/CE (Machinery Directive), 2014/53/UE (RED Directive). In order to ensure a suitable level of safety, besides complying with local regulations, it is advisable to comply also with the above mentioned Directives in all extra European countries.

⚠ **WARNING** Under no circumstances use the device in an explosive atmosphere or in areas that may be corrosive or could damage product parts. Check that the temperatures at the installation site are suitable and comply with the temperatures declared on the product label.

⚠ **WARNING** When working with the “dead man” switch, make sure that there are no people in the area where the automatism is being used.

⚠ **WARNING** Check that there is a switch or an omni polar magneto-thermal circuit breaker that enables complete disconnection in case of over voltage category III conditions installed upstream from the power system.

⚠ **WARNING** To ensure an appropriate level of electrical safety always keep the 230V power supply cables apart (minimum 4mm in the open or 1 mm through insulation) from low voltage cables (motors power supply, controls, electric locks, aerial and auxiliary circuits power supply), and fasten the latter with appropriate clamps near the terminal boards.

⚠ **WARNING** If the power cable is damaged, it must be replaced by the manufacturer or its technical assistance service or, in any case, by a person with similar qualifications to prevent any risk.

⚠ **WARNING** All installation, maintenance, cleaning or repair operations on any part of the system must be performed exclusively by qualified personnel with the power supply disconnected working in strict compliance with the electrical standards and regulations in force in the nation of installation.

Cleaning and maintenance destined to be performed by the user must not be performed by unsupervised children.

⚠ **WARNING** Using spare parts not indicated by **DEA** System and/or incorrect re-assembly can create risk to people, animals and property and also damage the product. For this reason, always use only the parts indicated by **DEA** System and scrupulously follow all assembly instructions.

⚠ **WARNING** Changing the closing intensity could lead to dangerous situations. Therefore, qualified personnel should only perform increases to the closing force. After adjustment, compliance with regulatory limits values should be detected with a force impact-measuring instrument. The sensitivity of the obstacle detection may be adjusted gradually to the door (see programming instructions). The anti-crushing device operation must be checked after each manual adjustment. Manual modification of the force can only be done by qualified personnel by performing the measurement test according to EN 12445. Modifications to the force adjustment must be documented in the machine manual.

⚠ **WARNING** The compliance of the internal sensing obstacles device to requirements of EN12453 is guaranteed only if used in conjunction with motors fitted with encoders.

⚠ **WARNING** Any external security devices used for compliance with the limits of impact forces must be conform to standard EN12978.

♻ **WARNING** In compliance with EU Directive 2012/19/EU on waste electrical and electronic equipment (WEEE), this electrical product should not be treated as municipal mixed waste. Please dispose of the product and bring it to the collection for an appropriate local municipal recycling.

EVERYTHING THAT IS NOT EXPRESSLY PROVIDED FOR IN THE INSTALLATION MANUAL IS NOT ALLOWED. CORRECT OPERATOR OPERATION IS ONLY ENSUED WHEN THE REPORTED DATA IS RESPECTED. THE COMPANY DOES NOT RESPOND FOR DAMAGE CAUSED BY FAILURE TO COMPLY WITH THE INSTRUCTIONS CONTAINED IN THIS MANUAL. WITHOUT AFFECTING THE ESSENTIAL FEATURES OF THE PRODUCT, THE COMPANY RESERVES THE RIGHT TO MAKE ANY CHANGES DEEMED APPROPRIATE AND AT ANY TIME IN ORDER TO TECHNICALLY, STRUCTURALLY AND COMMERCIALY IMPROVE THE PRODUCT WITHOUT BEING REQUIRED TO UPDATE THIS DOCUMENT.

2 PRODUCT DESCRIPTION

Models and contents of the package

The name GULLIVER identifies a series of electromechanical operators for industrial sliding gates with different features as to motor and control board power supply voltage, capacity, mechanical adjustment of force and built-in limit switch.

GULLIVER is completed by a set of accessories listed in the "PRODUCT ACCESSORIES" table (page I-6). This operator is composed of a mechanical gear motor which rotates the driving gear; This gear, coupled to the rack properly installed on the gate, converts the circular motion of the gear motor into rectilinear motion thus allowing the movement of the gate on its own guide.

Inspect the "Contents of the Package" (Pic. 1) and compare it with your product for useful consultation during assembly.

Transport

GULLIVER is always delivered packed in boxes that provide adequate protection to the product, however, pay attention to all information that may be provided on the same box for storage and handling.

3 TECHNICAL DATA

OPERATOR		
	18NET - 18NET/M - 18/IB - 1503E	25RRT - 25RRTF - 25RRT/M - 25/IB
Motor power supply voltage (V)	230 V ~ ±10% (50/60 Hz)	400 V ~ ±10% (50/60 Hz)
Absorbed power (W)	560	1200
Max Thrust (N)	1300	1650
Duty cycle (cycles/hour)	15 (leaf L=12m)	17 (leaf L=14m)
Maximum n° of operations in 24 hour	240	280
Built-in capacitor (µF)	30	-
Operating temperature range (°C)	-20 ÷ 50 °C	
Motor thermal protection (°C)	140 °C	-
Opening speed (m/min)	10	10
Weight of product with package (Kg)	30	
Sound pressure emitted (dBA)	< 70	
Protection degree	IPX4	
CONTROL BOARD		
NET230N		
Power supply (V)	230 V ~ ±10% (50/60 Hz)	
Fuse F2 (A)	5A	
Fuse F1 (A)	160mA	
230V operators outputs	2 x 600W	
Auxiliaries power supply output	24 V ~	(24V_AUX + 24V_ST = max 200mA)
Safety devices power supply output	24V ===	
"Warning" output	230 V ~ max 150W	
Electric lock output	max 1 art. 110 or 24V === output max 5W configurable	
230V Flashing light output	230 V ~ max 40W	
24V Flashing light output	24 V === max 100mA (for led flashing light) art. LED24AI or open gate warning light/courtesy light	
Operating temperature range (°C)	-20÷50 °C	
Receiver frequency	433,92 MHz	
Transmitters type of coding	HCS fix-code - HCS rolling code - Dip-switch	
Max remote controllers managed	100	

4 INSTALLATION AND ASSEMBLY

4.1 For a satisfactory installation of the product is important to:

- Ensure that the facility complies with current regulations and then define the full project of the automatic opening;
- Ensure that throughout the course of the gate, while opening and closing, there are no friction points;
- Ensure that there is no danger of derailment and that there are not risks that it goes out of the guides;
- Make sure the gate is in equilibrium: it must not move if it stays in any position;
- Ensure that the mounting area of the motor allows the release and a manual operation easier and safer;
- Ensure that the mounting positions of the various devices are protected from impacts and the surfaces are sufficiently robust;
- Do not allow the automation parts are immersed in water or other liquids.

4.2 Defined and satisfied these prerequisites, proceed to the assembly:

If the supporting plane is already available, the fixing of the motor must be done directly on the surface using, for example screw anchors or chemical means.

Alternatively, proceed as follows:

- Make a hole appropriate to the type of land by using as a reference the measurements shown in Fig 3;
- Provide an adequate number of channels for the passage of electrical cables;
- Place the base of the foundation;
- Start casting of concrete and, before you start taking, bringing the base plate to the dimensions shown in Figure 4, making sure that is parallel to the gate wing and perfectly level. Wait for the complete setting of the concrete;

If the rack is already present, place the pinion at a distance of 1-2 mm in order to avoid that the weight of the wing could burden on the gear motor (Fig. 5). To do this, adjust the height of GULLIVER shimming the base in an appropriate manner and then tighten the locking screws in a robust way (Fig. 6).

Alternatively, proceed as follows:

- Unlock the motor and fully open the door;
- Place the first section of the rack on the wing, making sure that the start of the rack corresponds to the top of the wing. Then attach the rack to the leaf keeping a game of 1-2 mm from the pinion (Fig. 5);
- Cut off the excess part of the rack;
- Finally, move the door manually several times and verify that the alignment and the distance of 1-2 mm between the rack and pinion is respected throughout the length;
- Tighten the locking screws of GULLIVER in a robust way (Fig. 6) and cover with plastic caps.

4.3 How to unlock the operator

Once you open the lock on the handle (protected by a plastic cover), the lever must be turned in the direction shown in Fig. 7, at this point the operator is unlocked and the gate, in the absence of other obstacles is free in his movements. The reverse process, turn the lever until it stops and closing of the lock (remember to protect the lock with the proper cover), keeps GULLIVER in working condition.

4.4 Limit-switches

Adjustment of the limit-switches

Some GULLIVER models provides a limit-switch whose intervention must be adjusted for each installation. **DEA** System provides two limit switches cams (Fig. 8) that are installed on the rack of the gate and subsequently regulated in such a way as to ensure the functionality and safety distances in opening and closing of the gate.

Keep in mind that when the limit switches trigger, the door will move to another 2-3 cm, and it's therefore suggested to fix the end of stroke brackets at a sufficient distance from the mechanical stops.

Adjustment of the magnetic limit switch

Attach the mounting brackets to the magnets as shown in Figure 10, making sure to mount the **LIGHT BLUE** magnet at the closing limit switch, the **GREEN** magnet at the end of the opening limit switch (Fig. 11). Connect the cable of the magnetic sensor which is colored **BROWN** at the FCC 1 input (Closing Limit Switch 1) and the **BLACK** one at FCA 1 input (Opening Limit Switch 1) (Fig. 12);

WARNING Refer to control board instructions to correctly identify the limit switch inputs.

WARNING Incorrect installation of the magnets can be dangerous to people or things; observe the conditions prescribed in these instructions.

Mount the magnetic sensor as shown in Fig. 9. The sensor must protrude from the bracket for supporting at least 35mm, in this way will avoid any interference.

Adjust the magnets support brackets so as to maintain a distance from the sensor between 10 and 20mm;

WARNING Opening and closing magnets positions are referred to a standard installation (operator placed on the left of the gate). In case of use of the parameter P063 (NET control boards only) for an inverted installation (operator on the right), the position of the magnets must not be changed.

In case of combination with the control panel art. 400RR, and only if you have to reverse the direction of travel of the geared motor, you will have to manually reverse the limit switch cables.

WARNING The electrical connections in this manual refer exclusively to the NET series control boards. If you are using GULLIVER with control board 212E or 400RR, please refer to the user manual of those control boards for all the wiring needed to startup the motor.

5 ELECTRICAL CONNECTIONS

Run the motor connections following the wiring diagrams.

WARNING For adequate electrical safety, keep low safety voltage wires (controls, electro-locks, antenna, auxiliary power) clearly separate from 230V ~ power wires (**minimum 4 mm in air or 1 mm via supplementary insulation**) placing them in plastic raceways and securing them with adequate clamps near terminal boards.

WARNING For connection to the mains, use a multipolar cable having a minimum section 3x1,5 mm² and complying with the current regulations. For connecting the motors, use a minimum cross section 1,5 mm² cable and complying with the current regulations. As an example, if the cable is out side (outdoor), must be at least equal to H05RN-F, whereas if it (in a raceway), must be at least equal to H05VV-F.

WARNING All wires must be striped and unsheathed in the immediate vicinity of terminals. Keep wires slightly longer to subsequently eliminate any excess.

WARNING Maintain the ground conductor at a major length respect the active conductors so that, if the cable exit from its fixing housing, the active conductors tighten up as first.

WARNING To connect the encoder to the control panel, use only a dedicated cable 3x0,75mm².

Program the control board to complete all adjustments. It is now possible to supply a complete installation in compliance with all standards required for gate automation. **See the instructions provided with the control panel to be connected.**

Finally, verify that all adjustments operations have been correctly performed and that safety devices and unlocking device properly work.

INTERNAL WIRING SET BY THE FACTORY
 EXTERNAL WIRING SET BY THE INSTALLER

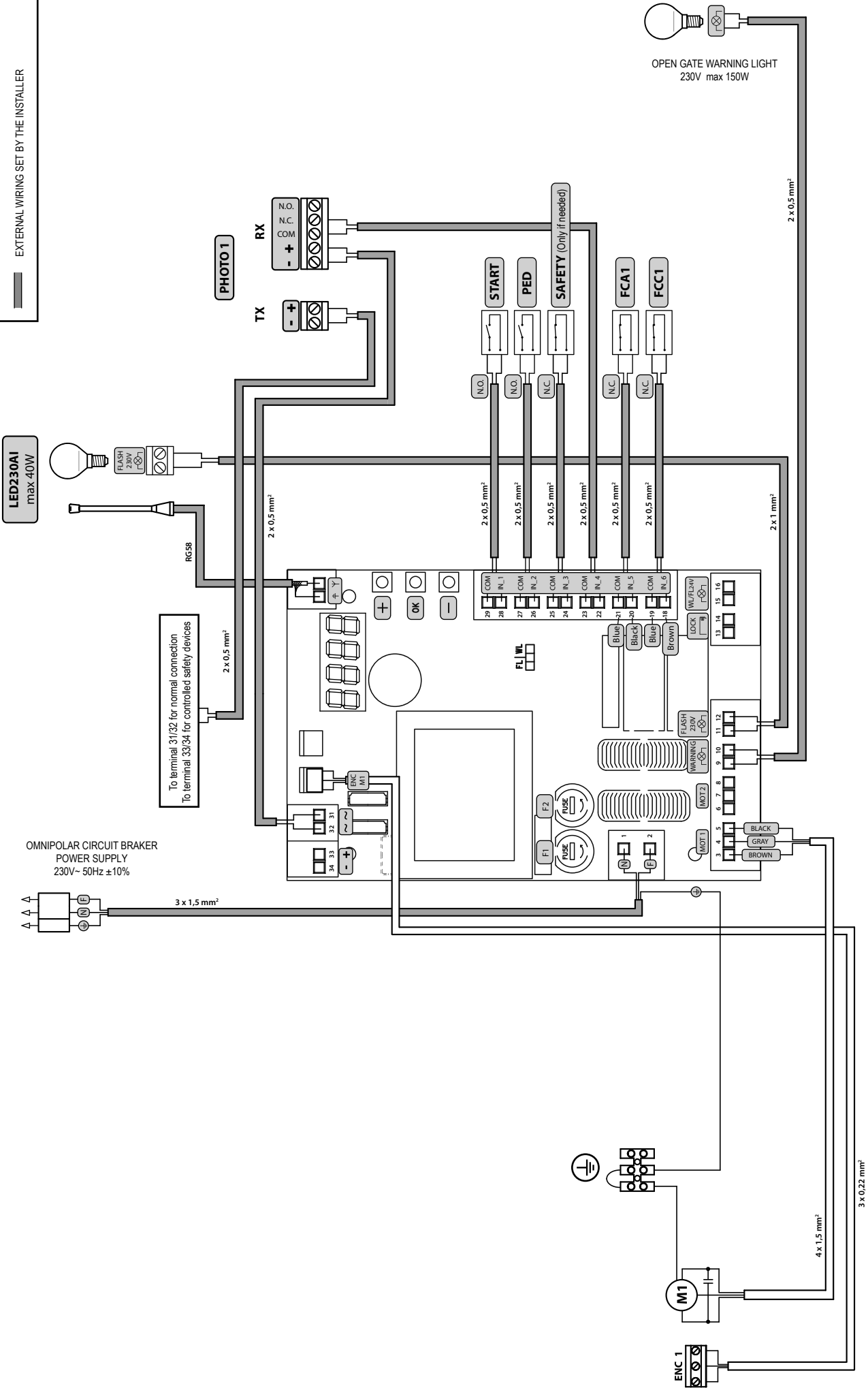

6 START-UP

The start-up phase is very important to ensure maximum security and compliance to regulations, including all the requirements of EN 12445 standard which establishes the test methods for testing the automation for gates.

DEA System reminds that all installation, maintenance, cleaning or repair operations on any part of the system must be performed exclusively by qualified personnel who must be responsible of all texts require by the eventual risk;

6.1 Installation test

The testing operation is essential in order to verify the correct installation of the system. **DEA System** wants to summarize the proper testing of all the automation in 4 easy steps:

- Make sure that you comply strictly as described in paragraph 2 "WARNINGS SUMMARY";
- Test the opening and closing making sure that the movement of the leaf match as expected. We suggest in this regard to perform various tests to assess the smoothness of the gate and defects in assembly or adjustment;
- Ensure that all safety devices connected work properly;
- Perform the measurement of impact forces in accordance with the standard 12445 to find the setting that ensures compliance with the limits set by the standard EN12453.

WARNING Using spare parts not indicated by **DEA System** and/or incorrect re-assembly can create a risk to people, animals and property and also damage the product. For this reason, always use only the parts indicated by **DEA System** and scrupulously follow all assembly instructions.

6.2 Unlocking and Manual operation

In the event of malfunctions or simple power failure, release the motor (Pic. 7) and perform the operation manually.

The knowledge of the unlocking operation is very important, because in times of emergency the lack of timeliness in acting on such a device can be dangerous.

WARNING The efficacy and safety of manual operation of the automation is guaranteed by **DEA System** only if the installation has been installed correctly and with original accessories.

7 MAINTENANCE

Good preventive maintenance and regular inspection ensure long working life. In the table below you will find a list of inspections/maintenance operations to be programmed and executed periodically.

Consult the TROUBLE-SHOOTING" table whenever anomalies are observed in order to find the solution to the problem and contact **DEA System** directly whenever the solution required is not provided.

INTERVENTION TYPE	PERIODICITY
cleaning of external surfaces	6 months
checking of screw tightening	6 months
checking of release mechanism operation	6 months
electric brake cleaning	6 months

TROUBLE-SHOOTING

Description	Possible solutions
When the opening or closing command is activated the gate leaf fails to move and the operator's electric motor fails to start.	The operator is not receiving correct power supply. Check all connections, fuses, and the power supply cable conditions and replace or repair if necessary. If the gate does not close check the correct functioning of photocells.
When the opening command is activated, the motor starts but the gate leaves fail to move.	Check that the unlocking system is closed (see Pic. 7).
	Check the electronic force adjustment device and the mechanical clutch.
The gate moves by fits and starts, it is noisy, it stops at half run or it does not start.	Make sure that the motor does not push in the opposite direction, the limit switch electrical connections might be reversed.
	Make sure that nothing hinders the gate wheels movement and the slide in which they roll.
	There always must be backlash between rack and pinion; make sure the rack is accurately positioned.
	The power of the gearmotor may be insufficient for the characteristics of the gate's wing; check the choice of model whenever requiredh.
	If the operator attachment to the gate bends or is badly fastened, repair and/or buttress it.

8 PRODUCT DISPOSAL

GULLIVER consists of materials of various types, some of which can be recycled (electrical cables, plastic, aluminum, etc. ..) while others must be disposed of (electronic boards and components).

Proceed as follows:

1. Disconnect the power supply;
2. Disconnect and disassemble all the accessories connected. Follow the instructions in reverse to that described in the section "Installation";
3. Remove the electronic components;
4. Sorting and disposing of the materials exactly as per the regulations in the country of sale.



WARNING In line with EU Directive 2012/19/EU for waste electrical and electronic equipment (WEEE), this electrical product must not be disposed of as unsorted municipal waste. Please dispose of this product by returning it to your local municipal collection point for recycling.

Esempio di installazione tipica - Example of typical installation - Exemple d'installation typique - Installationsbeispiel - Ejemplo de instalación típica - Exemplo de instalação típica - Przykład standardowego systemu automatyzacji - Пример типового монтажа

DEA System fornisce queste indicazioni che si possono ritenere valide per un impianto tipo ma che non possono essere complete. Per ogni automatismo, infatti, l'installatore deve valutare attentamente le reali condizioni del posto ed i requisiti dell'installazione in termini di prestazioni e di sicurezza; sarà in base a queste considerazioni che redigerà l'analisi dei rischi e progetterà nel dettaglio l'automatismo. - **DEA System** provides the following instructions which are valid for a typical system but obviously not complete for every system. For each automatism the installer must carefully evaluate the real conditions existing at the site. The installation requisites in terms of both performance and safety must be based upon such considerations, which will also form the basis for the risk analysis and the detailed design of the automatism. - **DEA System** fournit ces indications que vous pouvez considérer comme valables pour une installation-type, même si elles ne peuvent pas être complètes. En effet, pour chaque automatisations, l'installateur doit évaluer attentivement les conditions réelles du site et les pré-requis de l'installation au point de vue performances et sécurité ; c'est sur la base de ces considérations qu'il rédigera l'analyse des risques et qu'il concevra l'automatisation d'une manière détaillée. - Diese Angaben von **DEA System** können als gültig für eine Standardanlage angesehen werden, können aber nicht erschöpfend sein. So muss der Installationsfachmann für jedes Automatiksystem sorgfältig die Voraussetzungen des Installationsortes sowie die Leistungs- und Sicherheitsanforderungen an die Installation abwägen; aufgrund dieser Überlegungen muss er die Risikobewertung erstellen und genau das Automatiksystem entwickeln. -

DEA System facilita estas indicaciones que pueden considerarse válidas para una instalación tipo pero que no pueden considerarse completas. El instalador, en efecto, tiene que evaluar atentamente para cada automatismo las reales condiciones del sitio y los requisitos de la instalación por lo que se refiere a prestaciones y seguridad; en función de estas consideraciones redactará el análisis de riesgos y efectuará el proyecto detallado del automatismo. - **DEA System** fornece estas indicações que podem ser consideradas válidas para o equipamento padrão, mas que podem não ser completas. Para cada automatismo praticamente o técnico de instalação deverá avaliar com atenção as condições reais do sítio e os requisitos da instalação em termos de performance e de segurança; será em função destas considerações que realizará uma análise dos riscos e projectará. - **DEA System** dostarcza wskazówek, do wykorzystania w typowej instalacji ale nie będą one nigdy kompletne. Dla każdego typu automatyki, instalator musi sam oszacować realne warunki miejsca montażu i wymogi instalacyjne mając na uwadze przepisy dotyczące bezpieczeństwa. Na podstawie zebranych informacji będzie w stanie przeanalizować zagrożenia mogące wystąpić i zaprojektować w szczególności automatyzację. - **DEA System** предлагает рекомендации, которые действительны для типовой системы, но, очевидно, не обязательны для каждой конкретной установки. Для каждого конкретного случая установщик должен тщательно оценить реальные условия. Устройства для установки оцениваются с точки зрения производительности и безопасности, которые необходимы для анализа рисков и детального проектирования системы автоматизации.

Pos.	Descrizione - Description - Description - Beschreibung - Descripción - Descrição - Opis - Описание
1	Colonnina Pilly 60 - Pilly 60 column - Colonnnette Pilly 60 - Kleine Säule Pilly 60 - Columna Pilly 60 - Coluna Pilly 60 - Kolumnienka Pilly 60 - Pilly 60 столбик
2	GULLIVER
3	Fotocellule - Photocells - Photocellules - Fotozellen - Fotocélulas - Fotocélulas - Fotokomórki - фотоземеленты
4	Safety edge - Bord sensible - Berührungssensible Schaltleiste - Borde sensible - Dispositivo sensível de protecção - Listwa bezpieczeństwa - Ребро безопасности
5	Lampeggiante - Flashing light - Clignotant - Blinker - Lámpara - Intermitente - Lampa Ostrzegawcza - Сигнальная лампа
6	Selettore a chiave antiscasso - Anti lock-picking key switch - Sélecteur à clé anti-intrusion - Einbruchfester Schlüsselschalter - Selector a llave antisabotaje - Interruptor de chave burglar - Przełącznik kluczowy wandaloodporny - Замковый выключатель
7	Radiocomando - Remote-control - Radiocommande - Funksteuerung - Radiocomando - Comando via rádio - Nadajnik - Пульт ДУ
8	Selettore digitale - Radio keypad - Digicode radio - Digitalwahlschalter - Teclado digital radio - Teclado via rádio - Bezprzewodowa klawiatura - Радио кодовая панель

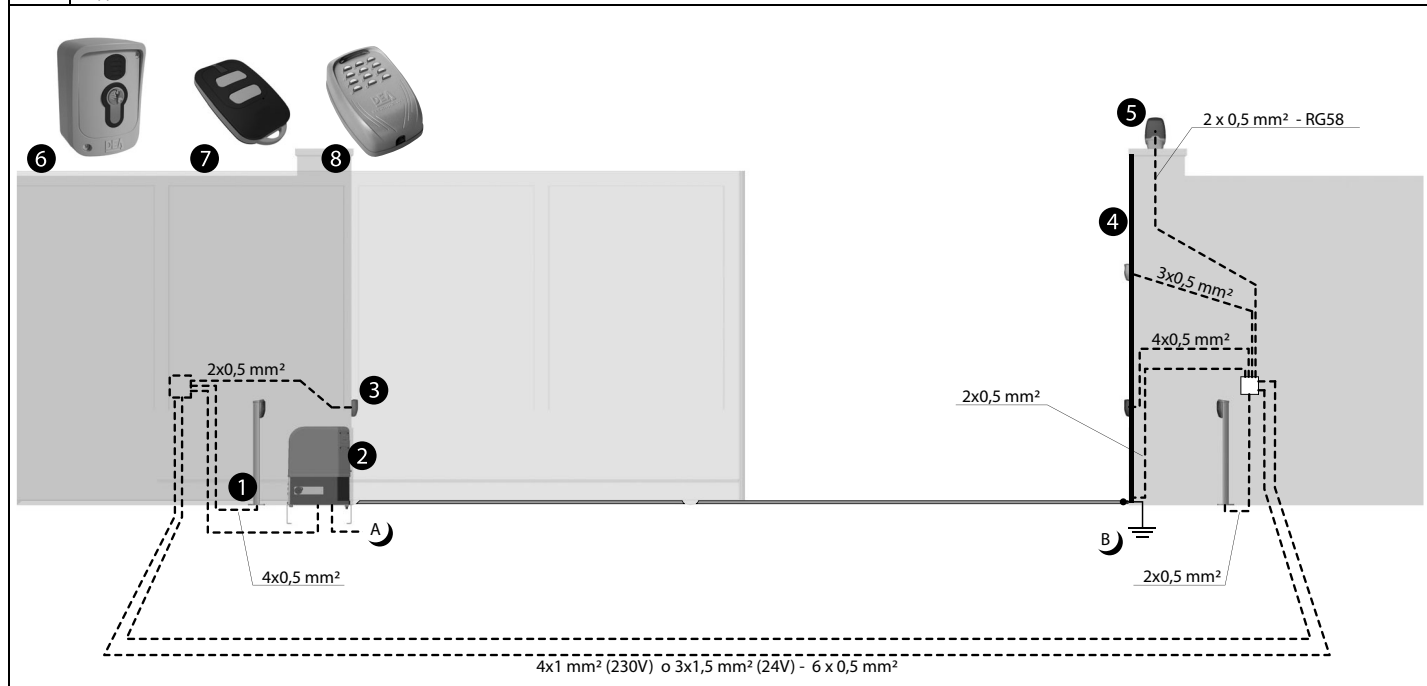

- A) Collegarsi alla rete 230 V ± 10% 50 Hz** tramite un interruttore onnipolare o altro dispositivo che assicuri la onnipolare disinserzione della rete, con una distanza di apertura dei contatti ≥ 3 mm - **Make** the 230V ± 10% 50 Hz mains connection using an omnipolar switch or any other device that guarantees the omnipolar disconnection of the mains network with a contact opening distance of 3 mm - **Connectez-vous** au réseau 230 V ± 10% 50 Hz au moyen d'un interrupteur omnipolaire ou d'un autre dispositif qui assure le débranchement omnipolaire du réseau, avec un écartement des contacts égal à 3 mm. - **Den** Anschluss an das 230 V ~ ± 10% 50 Hz Netz mit einem Allpolschalter oder einer anderen Vorrichtung vornehmen, durch die eine allpolige Netzunterbrechung bei einem Öffnungsabstand der Kontakte von ≥ 3 mm gewährleistet wird. - **Efectuar** la conexión a una línea eléctrica 230 V ± 10% 50 Hz a través de un interruptor omnipolar u otro dispositivo que asegure la omnipolar desconexión de la línea, con 3 mm de distancia de apertura de los contactos. - **Ligue** na rede de 230 V ± 10% 50 Hz mediante um interruptor omnipolar ou outro dispositivo que assegure que se desliga de maneira omnipolar da rede, com abertura dos contactos de pelo menos 3 mm. de distância - **Podłączyć** się do sieci 230 V ± 10% 50 Hz poprzez przełącznik jednobiegunowy lub inne urządzenie które zapewni brak zakłóceń w sieci, przy odległości między stykami ≥ 3 mm. - **Подключайтесь** к сети 230V ± 10% 50 Гц с помощью многополюсного выключателя или используйте любое другое устройство, которое гарантирует многополюсное отключение питающей сети с расстоянием между контактами от ≥ 3 мм и больше.
- B) Collegare a terra tutte le masse metalliche** - **All** metal parts must be grounded - **Connectez** toutes les masses métalliques à la terre - **Alle** Metallteile erden - **Conectar** con la tierra todas las masas metálicas - **Realize** ligação à terra de todas as massas metálicas - **Uziemić** wszystkie elementy metalowe. - **Все** металлические части должны быть заземлены.

1

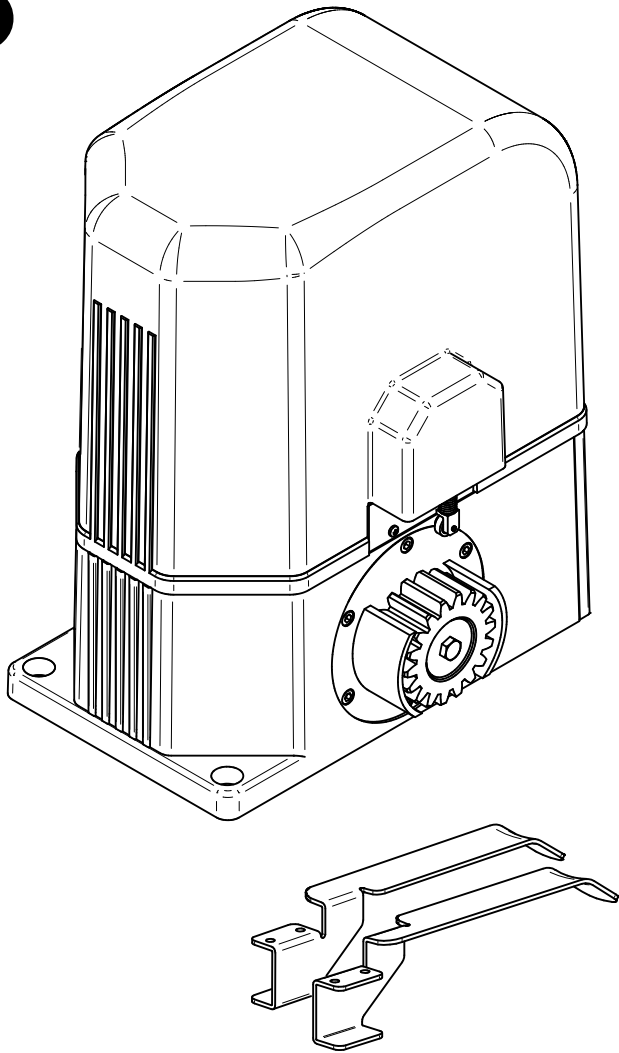

-  4
-  4
-  4
-  4

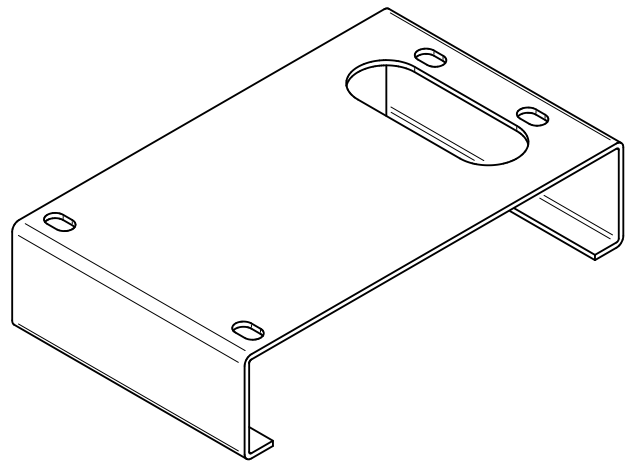

2

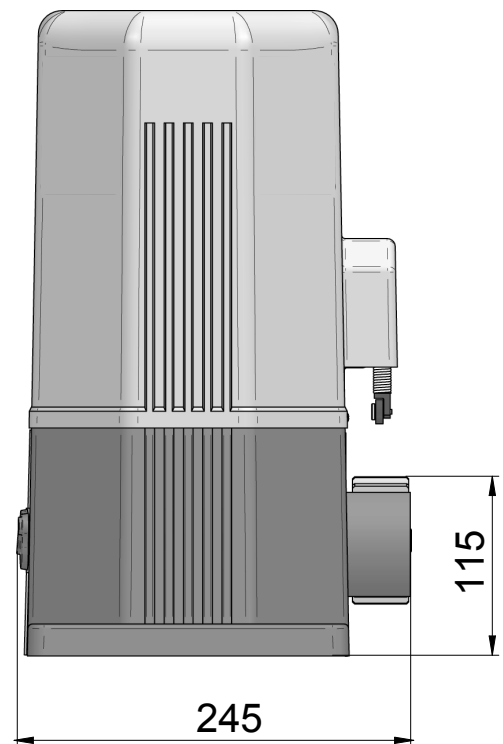
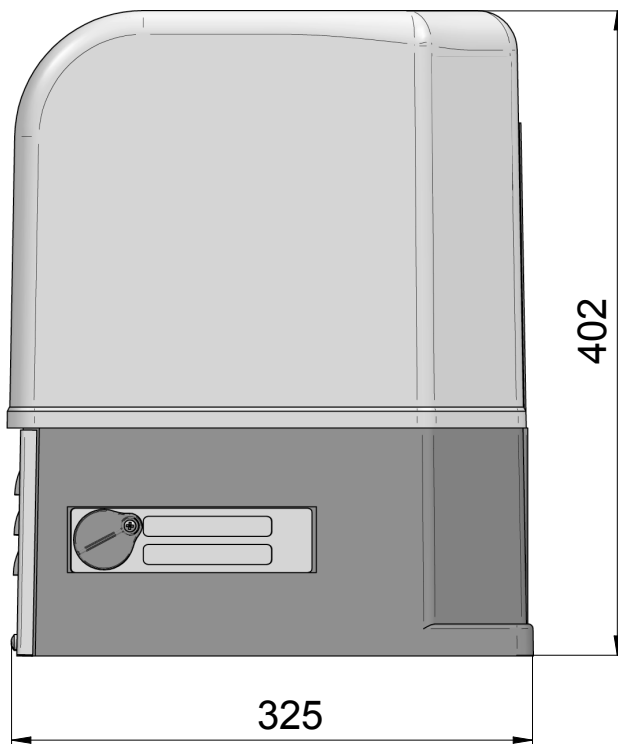

3

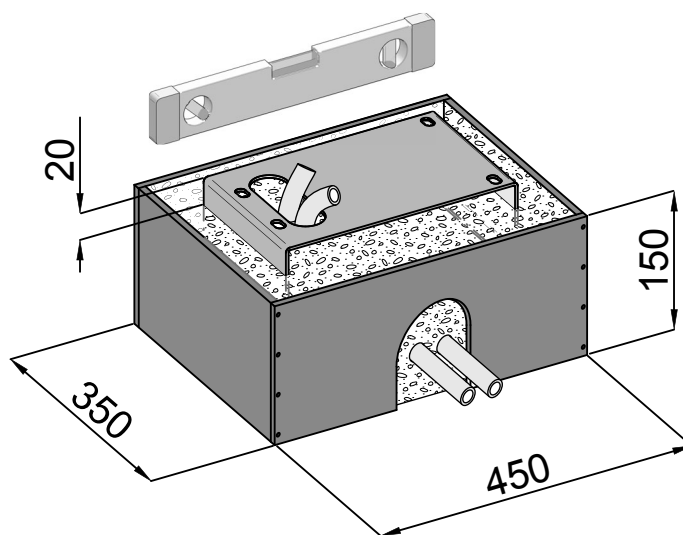
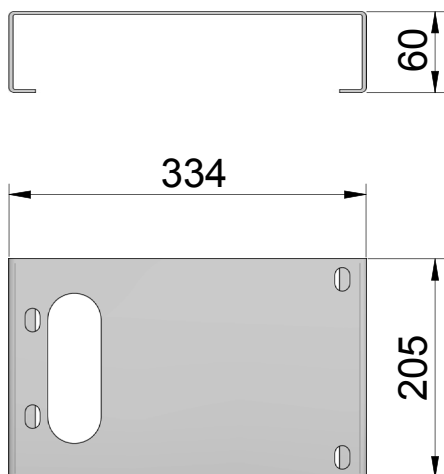

4

Anta cancello, Door gate, Leaf, Schiebetor, Hoja, Folha, Brama, Створка ворот

Base di fondazione, Foundation plate, Plaque de fondation, Fundamentplatte, Placa de cimentación, Placa de fundação, Płyta fundamentowa, Закладная пластина

Cremagliera, Rack, Crémaillère, Zahnstange, Cremaliera, Cremalheira, Zębatka, Зубчатая рейка

Struttura fissa, Fixed structure, Structure fixe, Wand, Estructura fija, Estrutura fixa, Stala struktura, Зафиксированное основание

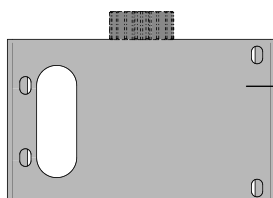

Cavi, Cables, Câbles, Verdrahtung, Cables, Cabos, Kable, Кабели

20 mm.

117 mm.

105 mm.

Pozzetto in cemento, Concrete shaft, Enveloppe de béton, Betonschacht, Fuste de hormigón, Eixo de concreto, Wał betonowy, Бетонный фундамент

5

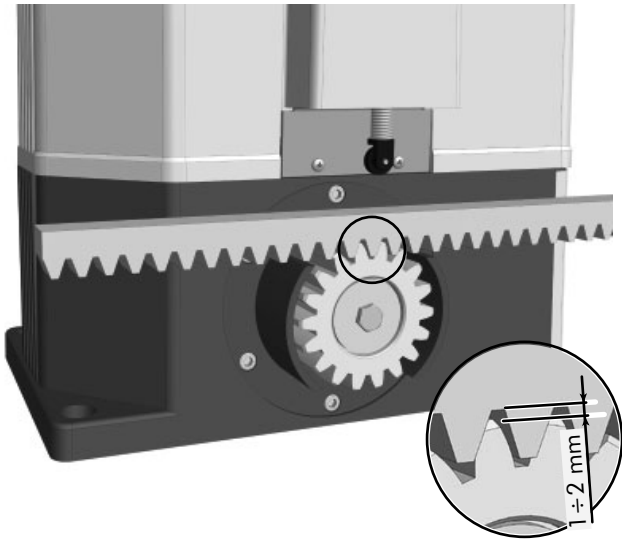

6

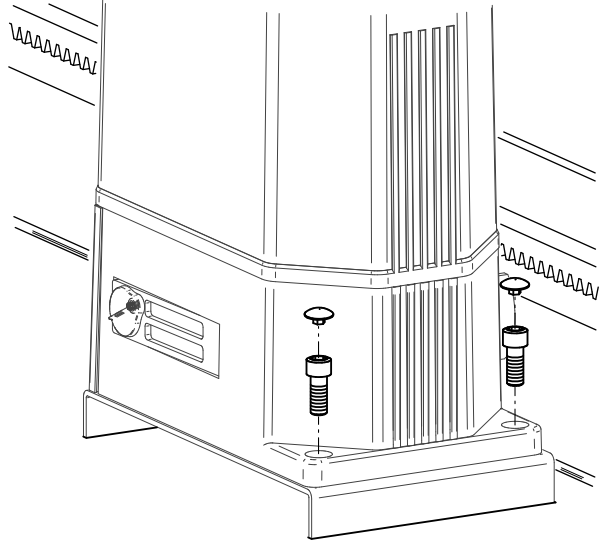

7

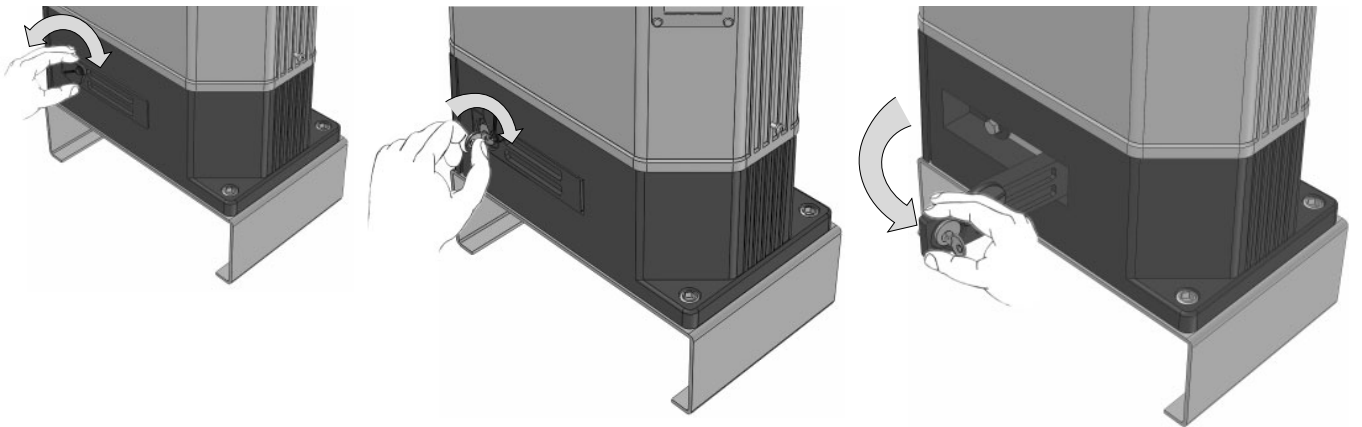

8

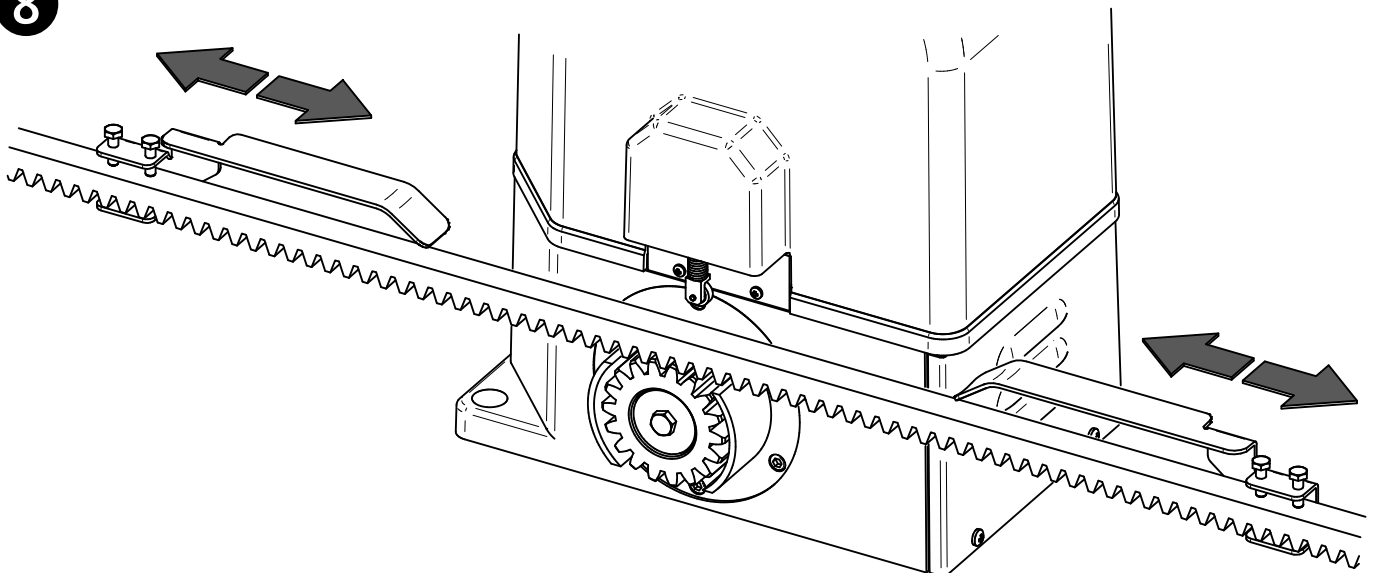

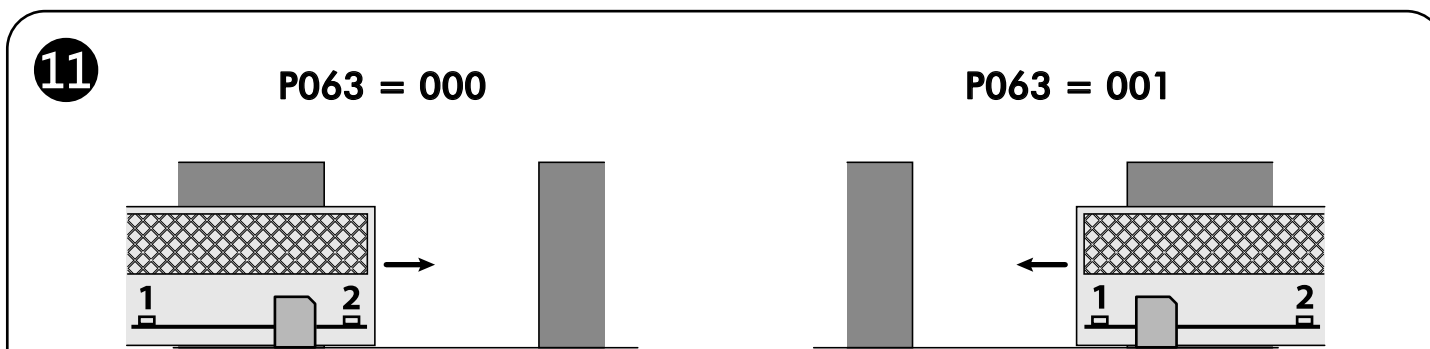
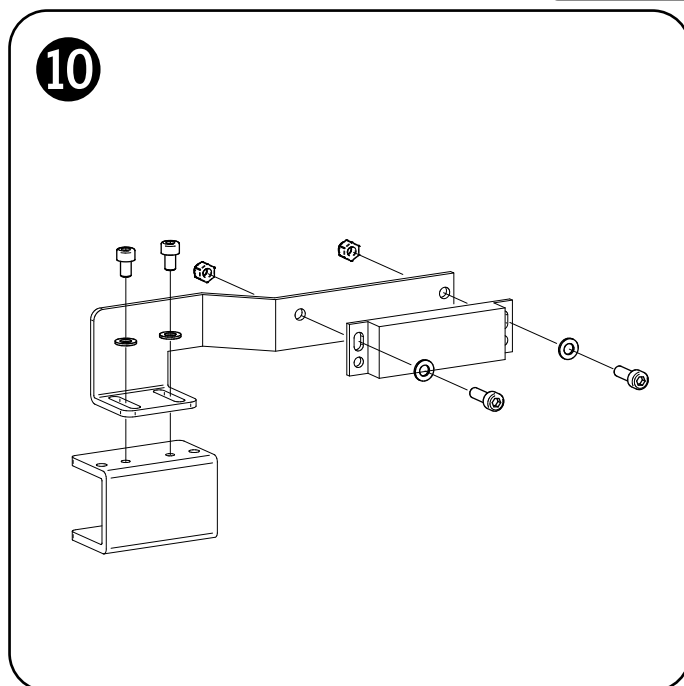
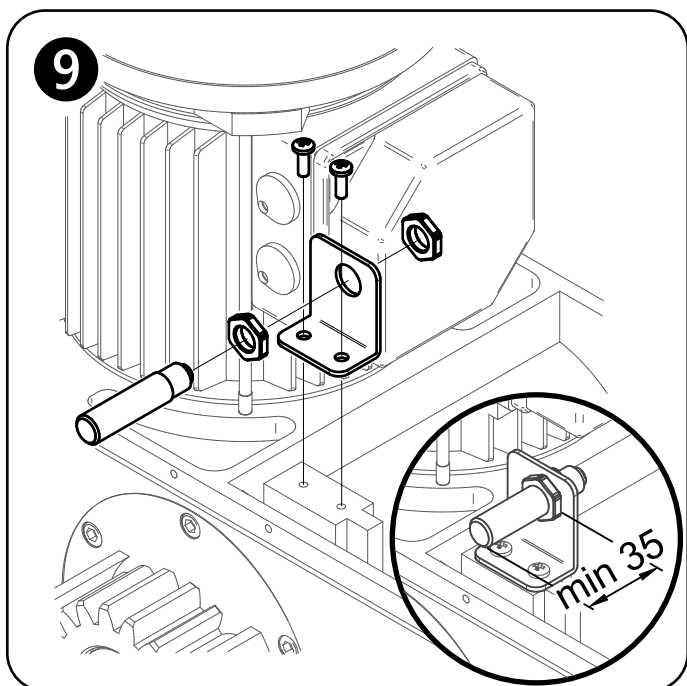

Pos.	Description	Pos.	Description
1	Azzurro, light blue, bleu, hellblau, azul, niebieski, светло-голубой	2	Verde, green, vert, grün, verde, zielony, зеленый

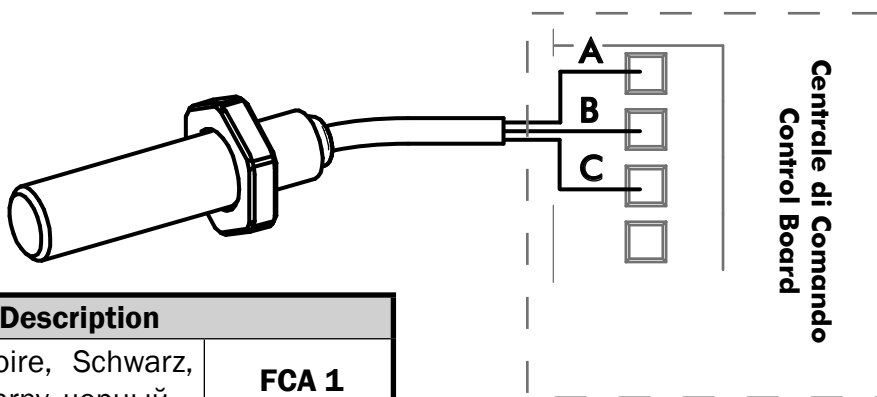

ATTENZIONE: In caso di utilizzo del parametro P063 (solo centrali serie NET) per l'installazione invertita del motore (motore a destra), la posizione dei magneti non deve essere modificata. - **WARNING:** In case of use of the parameter P063 (NET control boards only) for an inverted installation (operator on the right), the position of the magnets must not be changed. - **ATTENTION:** En cas d'utilisation du paramètre P063 (seulement pour platines de la série NET) pour l'installation du moteur inversé (à droite), la position des aimants ne doit pas être modifiée. - **ACHTUNG:** Bei Verwendung des Parameters P063 (nur bei Steuerungen der Baureihe NET) für die umgekehrte Installation des Motors (Motor rechts) darf die Magnetenposition nicht verändert werden. - **ATENCIÓN:** En caso se utilice el parámetro P063 (solo cuadros de la serie NET) para la instalación del motor al otro lado (motor a la derecha), la posición de los imanes no debe ser modificada. - **ATENÇÃO:** No caso de utilizar o parâmetro P063 (apenas centrais de comando NET) para uma instalação invertida (motor no lado direito), a posição dos magnetos não pode ser alterada. - **UWAGA:** W przypadku zastosowania parametru P063 (tylko centrale sterujące serii NET), przy odwróconej instalacji silnika (silnik z prawej), położenie magnesów nie musi być zmieniane. - **ВНИМАНИЕ:** В случае использования параметра P063 (только для платы NET) для зеркальной установки (привод справа), положение магнитов следует поменять местами вручную.

12



Pos.	Description	
A	Nero, Black, Noire, Schwarz, Negro, Preto, Czarny, черный	FCA 1
B	Blu, Blue, Bleu, Blau, Azul, Niebieski, Синий	COM
C	Marrone, Brown, Marron, Braun, Marrón, Marrom, Brąz, коричневый	FCC 1

Tabella "ACCESSORI PRODOTTO", Table "PRODUCT ACCESSORIES", Tableau "ACCESSOIRES PRODUITS",
Tabelle „PRODUKTZUBEHÖRTEILE”, Tabla "ACCESORIOS PRODUCTO", Tabela "ACESSÓRIOS DO PRODUTO",
Tabell "AKCESORIA DODATKOWE", Таблица "АКСЕССУАРЫ ИЗДЕЛИЯ".

Article Code	Descrizione, Description, Description, Beschreibung Descripción, Descrição, Opis, Описание	
111 619000		Cremagliera in NYLON , NYLON rack, Crémaillère NYLON , Zahnstange aus NYLON, Cremallera NYLON , Cremalheira NYLON, Listwa zębata NYLONOWA , Нейлоновая зубчатая рейка
112 126001		Cremagliera ZINCATA 22x22 , ZINC PLATED rack 22x22, Crémaillère ZINGUÉE 22x22 , Eisenzahnstange verzinkt 22x22, Cremallera GALVANIZADA 22x22 , Cremalheira ZINCADA 22x22, Listwa zębata METALOWA do spawania 22x22 , Зубчатая рейка оцинкованная 22x22
113 126000		Cremagliera ZINCATA 30x12 , ZINC PLATED rack 30x12, Crémaillère ZINGUÉE 30x12 , Eisenzahnstange verzinkt 30x12, Cremallera GALVANIZADA 30x12 , Cremalheira ZINCADA 30x12, Listwa zębata METALOWA do przykręcenia 30x12 , Зубчатая рейка оцинкованная 30x12

INSTRUCTIONS FOR THE FINAL USER

This guide has been prepared for the final users of the automatism; the installer is required to deliver this guide and illustrate its contents to the person in charge of the system. The latter must then provide similar instruction to all the other users. These instructions must be carefully conserved and easily available for consultation when required.

Good preventive maintenance and frequent inspection ensures the long working life of the product. Contact the installer regularly for routine maintenance and in event of anomaly.

SAFETY RULES

1. Always keep a safe distance from the automatism during operation and never touch any moving part.
2. Prevent children from playing near the automatism.
3. Perform the control and inspection operations prescribed in the maintenance schedule and immediately stop using the automatism whenever signs of malfunction are noted.
4. Never disassemble parts of the product! All maintenance and repair operations must be performed only by qualified personnel.
5. The release operation must sometimes be performed in emergencies! All users must be instructed on the use of the release mechanism and the location of the release keys.

GULLIVER RELEASE MECHANISM

All GULLIVER models have an unlocking system; the working of this system is the following: after unlocking the lock on the handle (protected by a plastic cover) turn the lever in the direction shown in figure; the operator is now unlocked and, if no obstructions hinder its movement, the gate can now move freely. The opposite procedure, that is the rotation of the lever up to the limit switch and the locking of the lock (remember to protect the lock with the appropriate cover) returns GULLIVER to its normal working conditions.

WARNING: During this operation gate may present uncontrolled movement: operate with extra care so to avoid any risk.

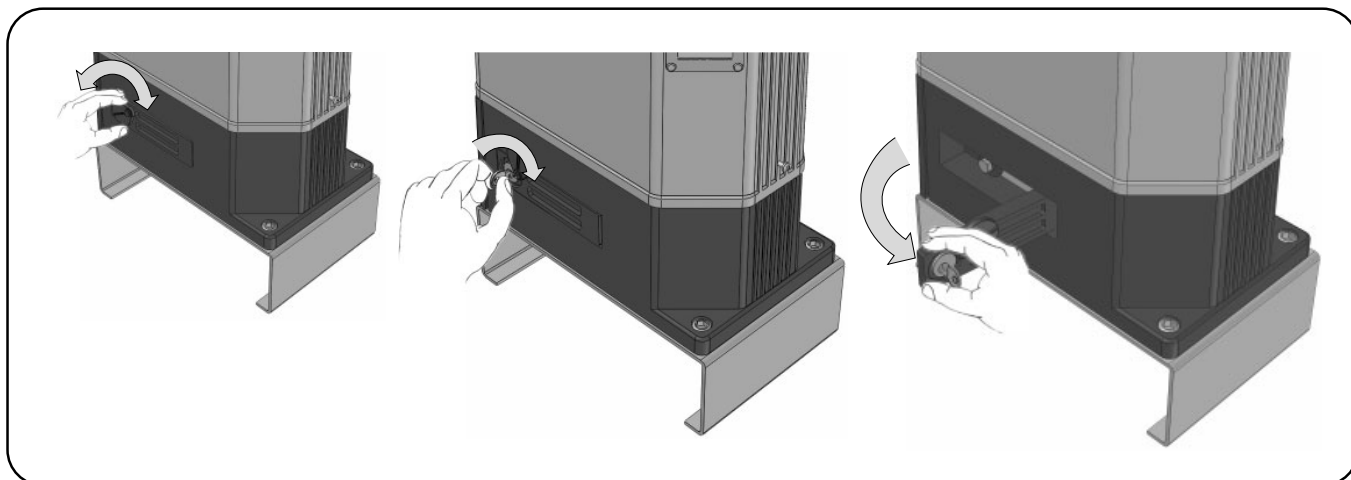

CLEANING AND INSPECTIONS

The only operation that the user can and must do is to remove branches, leaves, and any other object that might obstruct the gate's free movement. Warning! Always disconnect the power supply whenever performing operations on the gate!



EU Declaration of Conformity (DoC)

and Declaration of Incorporation of "quasi-machines" (pursuant to the Machinery Directive 2006/42/CE, Att.II, B)

Company name:	DEA SYSTEM S.p.A.
Postal address:	Via Della Tecnica, 6
Postcode and City:	36013 Piovene Rocchette (VI) - ITALY
Telephone number:	+39 0445 550789
E-Mail address:	deasystem@deasystem.com

declare that the DoC is issued under our sole responsibility and belongs to the following product:

Apparatus model/Product:	18NET - 18NET/M - 18/IB - 1503E - 25RRT - 25RRTF - 25RRT/M - 25/IB
Type:	GULLIVER Electromechanical operators for industrial sliding gates
Batch:	See the label on the back of the user manual

The object of the declaration described above is in conformity with the relevant Union harmonisation legislation:

Directive 2006/42/CE (MD Directive)

- It is declared that the relevant technical documentation has been drawn-up in compliance with attachment VII B.
- It is also declared that the following essential health and safety requirements have been respected: 1.1.1 - 1.1.2 - 1.1.3 - 1.1.5 - 1.2.1 - 1.2.6 - 1.3.1 - 1.3.2 - 1.3.3 - 1.3.4 - 1.3.7 - 1.3.9 - 1.5.1 - 1.5.2 - 1.5.4 - 1.5.5 - 1.5.6 - 1.5.7 - 1.5.8 - 1.5.10 - 1.5.11 - 1.5.13 - 1.6.1 - 1.6.2 - 1.6.4 - 1.7.2 - 1.7.3 - 1.7.4 - 1.7.4.1 - 1.7.4.2 - 1.7.4.3.
- The undersigned declares that the afore-mentioned "partly-completed machinery" cannot be commissioned until the final machine, into which it has been incorporated, has been declared compliant with the Machinery Directive 2006/42/CE.
- On duly justified request, the manufacturer commits to transmitting the information regarding the "partly-completed machinery" to the national authorities without prejudice to their intellectual property rights.

The product is in compliance with the applicable parts of the following regulations:
EN 60335-2-103:2015; EN 12453:2017.

Directive 2014/53/UE (RED Directive)

Directive 2011/65/EU (RoHS)

The following harmonised standards and technical specifications have been applied:

Title:	Date of standard/specification
EN61000-6-2	2005 + EC:2005
EN61000-6-3	2007 + A1:2011
EN301 489-1 v2.1.1	2017
EN301 489-3 v2.1.1	2017 final draft
EN60335-1	2012 + EC:2014 + A11:2014
EN62233	2008
EN300 220-1 v3.1.1	2017
EN300 220-2 v3.1.1	2017
EN50581	2012

Additional information

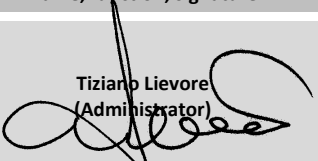
Signed for and on behalf of:		
Revision:	Place and date of issue:	Name, function, signature
01.03	Piovene Rocchette (VI) 18/03/19	 Tiziano Lievore (Administrator)

BATCH



DEA SYSTEM S.p.A.

Via Della Tecnica, 6 - 36013 PIOVENE ROCCHETTE (VI) - ITALY

tel: +39 0445 550789 - **fax:** +39 0445 550265

Internet: <http://www.deasystem.com> - **E-mail:** deasystem@deasystem.com